

ERECTOR NOTE :-
ENSURE DDI END BRACKETS ARE ALIGNED TO GIVE FREE VERTICAL MOVEMENT OF IDLER SUPPORT FRAME.

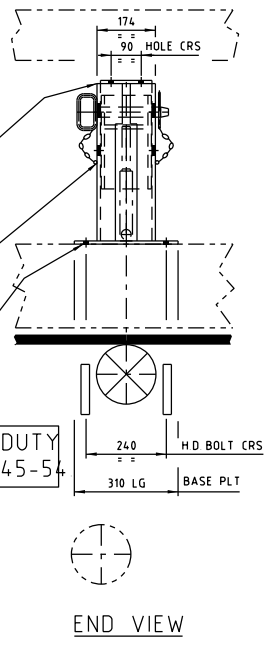
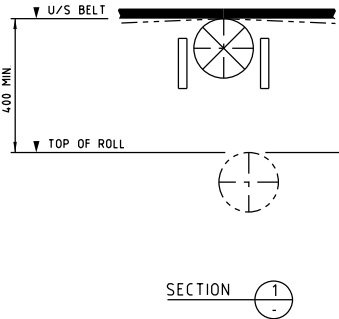
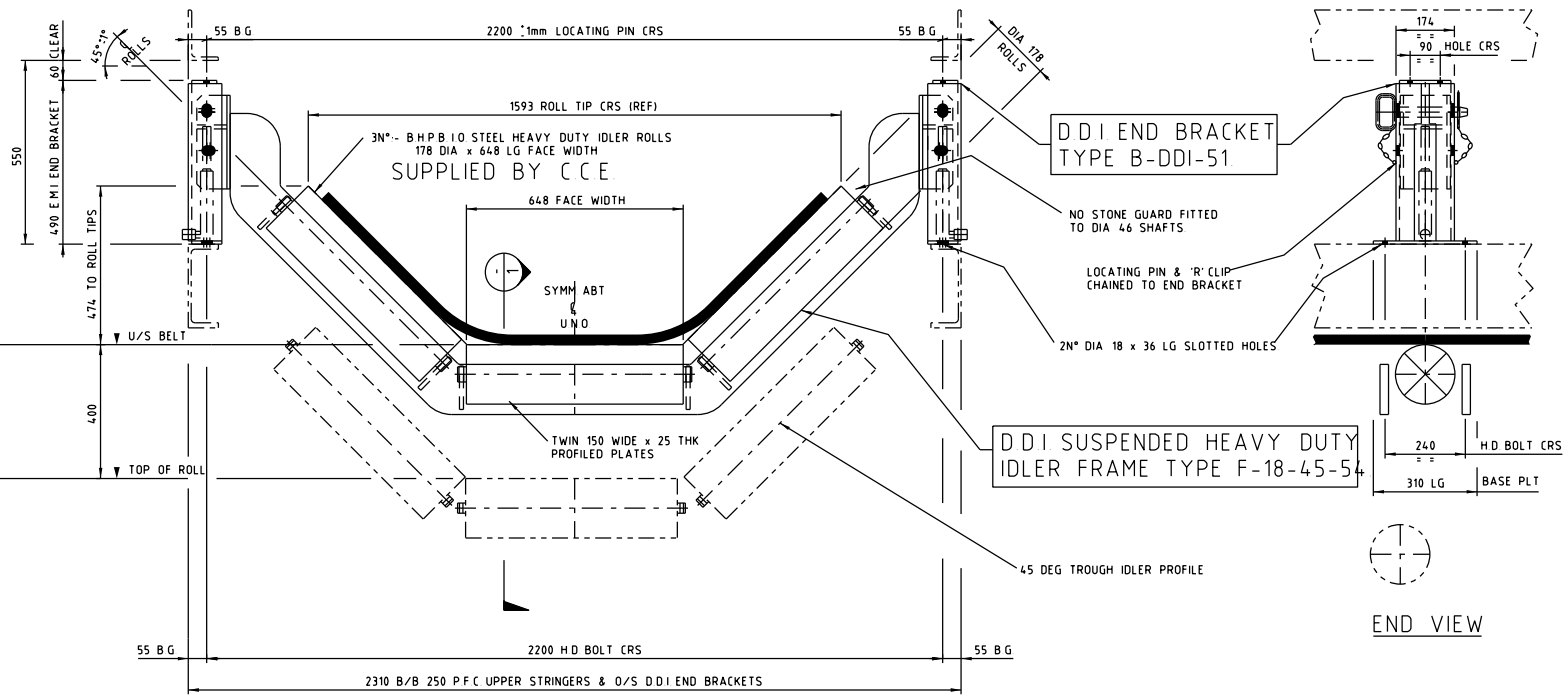

3	ROLLER DIA 178 x 648 FACE BEARING TYPE - 22313 C-RATING 25.0 KN	A178Z0664K0F00	3
2	END BRACKET	B-DDI-51	2
1	FRAME	F-18-45-54	1
ITEM	DESCRIPTION	PART No	QTY

AREA C RGP3
CONVEYOR REFERENCE
MC301 MC302

STANDARD DDI SUSPENDED HEAVY DUTY IDLER - IN OPERATIONAL POSITION

DIMENSIONAL TOLERANCES UN

UP TO 50mm	: 0.5	316-1000mm	: 2.0
51-315mm	: 1.0	1001mm-OVER	: 3.0

GENERAL FABRICATION NOTES

- STEELWORK TO AS3679-300, AS1163-350.
- ALL WELDS 5mm CONT FILLET TO AS1154-1SP U/M
- FRAME TO BE FREE OF WELD SPLATTER & DROSS
- SURFACE FINISH :-
- FRAME TO BE HOT DIP GALVANIZED AS PER BHPB 10 SPEC 001-M-00004 CLAUSE 3.8.2
- ROLLER ENDS TO BE PAINTED AS PER BHPB 10 SPEC 001-M-00004 CLAUSE 3.8.2

SPECIFIC DATA

- TOTAL IDLER ASSY MASS - 507.0kg (WITH ROLLERS)
2310kg (WITHOUT ROLLERS)
- MASS OF ROTATING COMPONENTS - 187.5kg
- MASS OF SINGLE ROLLER - 91.9kg
- MOMENT OF INERTIA OF A SINGLE ROLLER - 0.3352 kg m²
- DYNAMIC LOAD CAPACITY OF IDLER ASSEMBLY BASED ON 5.0 m/s BELT SPEED & 75000 HR L10 BRG LIFE - N/A
- FOR A SINGLE ROLLER UNDER LOAD CONDITIONS DESCRIBED IN e) ABOVE & WITH AN AMBIENT TEMP OF 20°C THE TANGENTIAL FORCE REQ'D TO :
i) START ROTATION - 9 N
ii) MAINTAIN ROTATION AT 5.0 m/s - 8 N

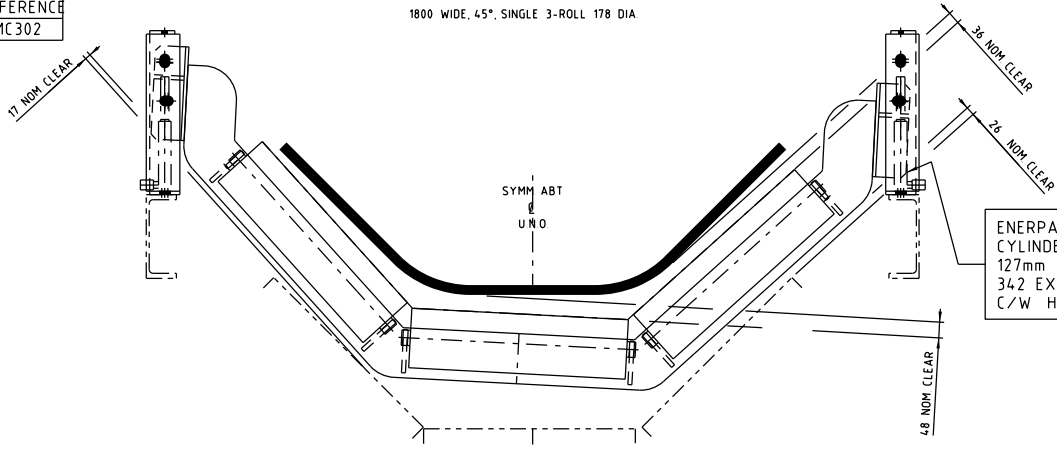

STANDARD DDI SUSPENDED HEAVY DUTY IDLER - IN MAINTENANCE POSITION

H&B H & B DRAWING No -
A-18-45-54
1000 x 45 DEG 3 - ROLL
00178 5-H/D
JOB No HB727

SCALE	AS	CLIENT	BHP BILLITON	PROJECT	MINE ORE HANDLING - AREA C CONVEYOR																
DRAWN	AS	DRAWING TITLE	DDI ASSEMBLY GENERAL ARRANGEMENT	CLIENT DRG No.	860-M-00501/0																
CHECKED	AS	MARK	A-18-45-54	H & B DRG No.	A-18-45-54																
DESIGNED	AS	REV																			
DESIGN CHECK	AS																				
PROJECT APP.	AS																				
AP FOR CONST	AS																				
ISSUED FOR CONSTRUCTION	AS	DRN	CHD	APP	Nº																
ISSUED FOR PRELIMINARY APPROVAL	AS	DRN	CHD	APP	Nº																
DRG NUMBER	REFERENCE DRAWING TITLE	Nº	DATE	REVISIONS	DRN	CHD	APP	Nº	DATE	REVISIONS	DRN	CHD	APP	Nº	DATE	REVISIONS	DRN	CHD	APP	Nº	DATE





Head Office
7 Tahiti Lane, Hillarys, Perth,
Western Australia
Phone: (08) 9403 2993

Email: info@handbmining.com.au

www.handbmining.com.au

H & B Mining: “The Experts in Conveyor Skirts”

H & B Mining design and supply a range of “Easy Maintenance” conveyor transfer products to the Australian mining industry with the aim of providing a safer, easier to maintain and more efficient working environment at conveyor transfer points.

H & B Mining was established in April 1993 with the promise of providing a standalone conveyor design service tailored to accommodate the mines of Australia. After witnessing maintenance crews struggling to maintain and change out poorly designed products for conveyor transfers H & B decided to expand its portfolio by developing its own range of ‘Easy Maintenance Products’ for conveyor transfer points including: conveyor idlers, conveyor skirting systems, hinged dust covers, conveyor guards, conveyor diversion plough, streamline conveyor transfer design and the retractable loading boot.

The “Easy Maintenance” conveyor product range harnesses H & B’s vast experience in the field along with the innovative design technology nurtured over the years within the H & B design team. The Australian mining industry has benefited from H & B’s toil, witnessing enhanced overall productivity, reduced shutdown time and improved safety whilst gaining cost effective mining conveyor operations. H & B Mining products have been installed as mine standard by Rio Tinto, BHP Billiton, Roy Hill and FMG, amongst others.

Drop Down Idler

The H & B easy maintenance drop down idler provides a quick, easy, safe and economical way to change out worn or damaged idler rollers on a mining conveyor.

One person can change out rollers by removing a locking pin to release the roller support frame from its operational position. A bottle jack or hydraulic cylinder is then used to lower the roller support frame away from the conveyor belt to create an opening between belt and rollers sufficient enough to allow access for removal or insertion of rollers without the need to lift the belt. Incorporating such an easy maintenance system ensures that worn rollers are changed out on a regular basis which in turn guarantees a consistent belt line beneath the skirted area.

A consistent belt line with a well maintained skirting system reduces spillage down to an absolute minimum, eliminates material build up around transfer areas and generally enhances the overall productivity of the conveyor materials handling system.